

# VAB-600-C

Daughter board for VAB-600 Pico-ITX mainboard

## Quick Guide

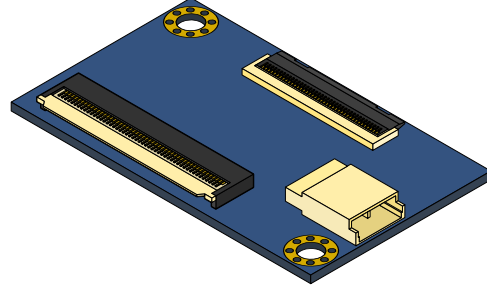

### Key Features:

- Allows TTL display supported by VAB-600 mainboard
- Quick installation and easy setup

The VAB-600-C is a TTL converter board specially designed for VAB-600 Pico-ITX mainboard. By connecting the VAB-600-C to the VAB-600 mainboard, TTL display can be fully supported. VAB-600-C is equipped with 3 I/O ports which are DVO signal connector, TTL panel signal connector and backlight connector.

### Specifications:

- **PCB Size**
  - 46mm x 25mm x 1mm (L x W x H)
  - 4-layer
- **I/O Connector**
  - DVO signal connector
  - TTL panel signal connector

### Package Lists:

- 1 x VAB-600-C daughter board
- 1 x DVO flex cable

### Notes:

Please ensure that all items in the packing list are present before using this product. If any of the items are missing or damaged, contact your distributor or sales representative immediately.

## Layout Diagram

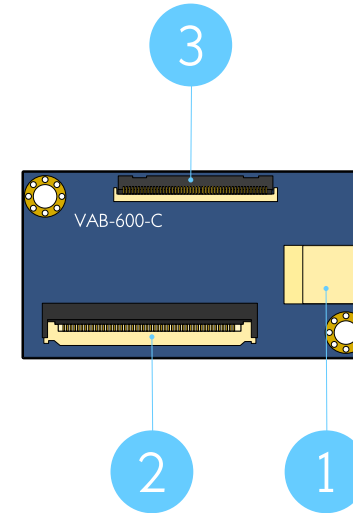

Item	Description
1	CN2: Backlight connector
2	CN1: DVO connector
3	LCD1: TTL panel connector

## Dimension

### Top view

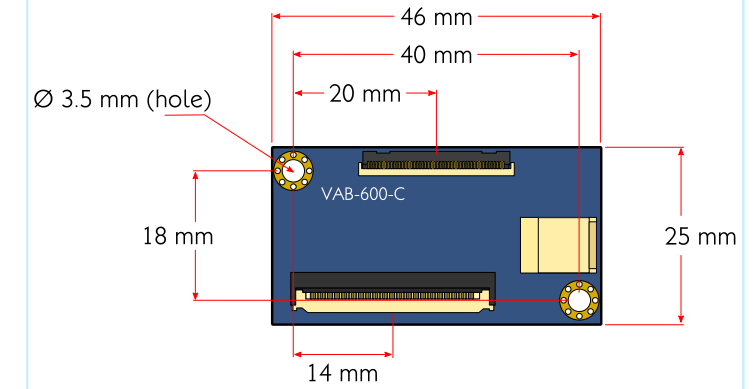

### Side view

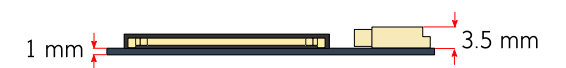

## 1 Installing VAB-600-C to VAB-600 mainboard

### Step 1

Install the VAB-600-C daughter board to a suitable surface and secure it with 2 screws.

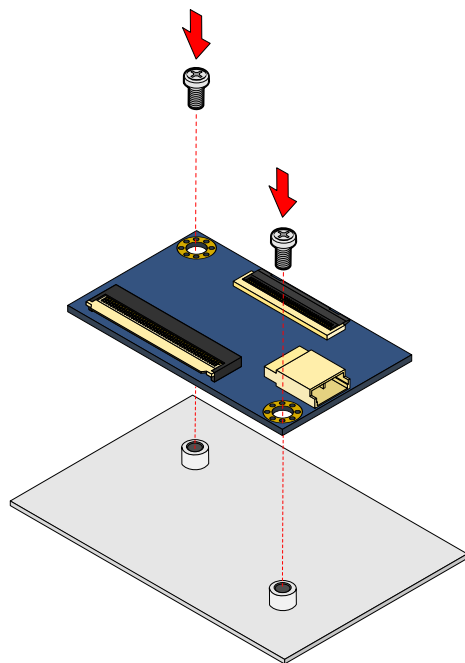

### Step 2

Connect one end of the DVO flex cable to the DVO connector (CN1) on VAB-600-C daughter board and the other end to DVO connector (CN13) on VAB-600 mainboard.

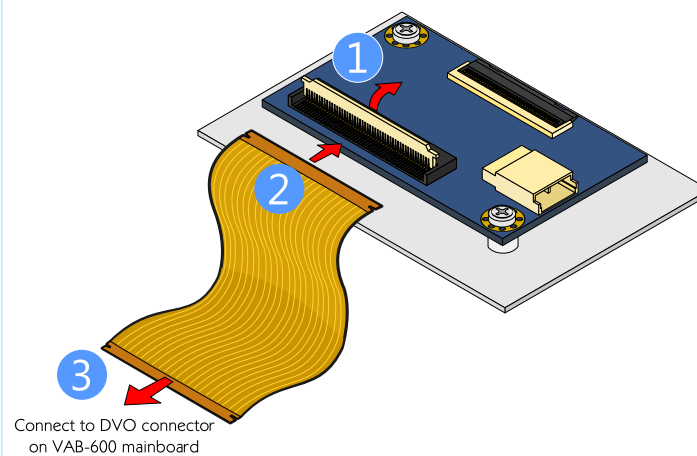

### Step 3

Connect the TTL panel flex cable to TTL panel connector (LCD1) on VAB-600-C.

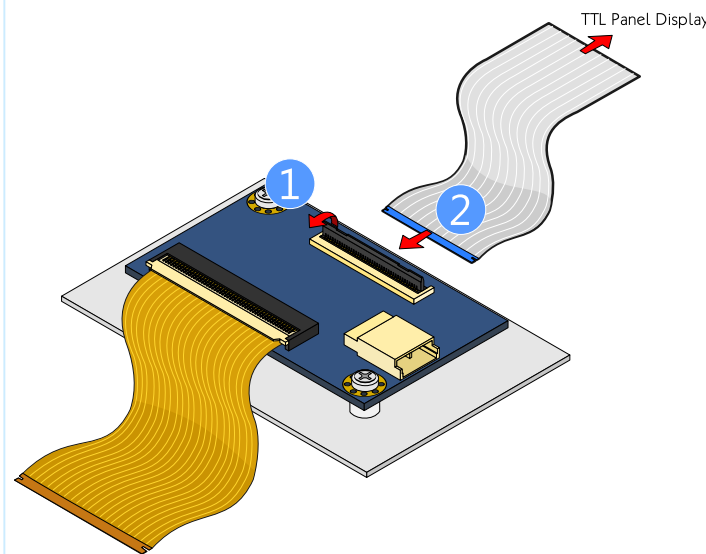

### Step 4

Connect backlight cable of TTL panel to the backlight connector (CN2) on VAB-600-C.

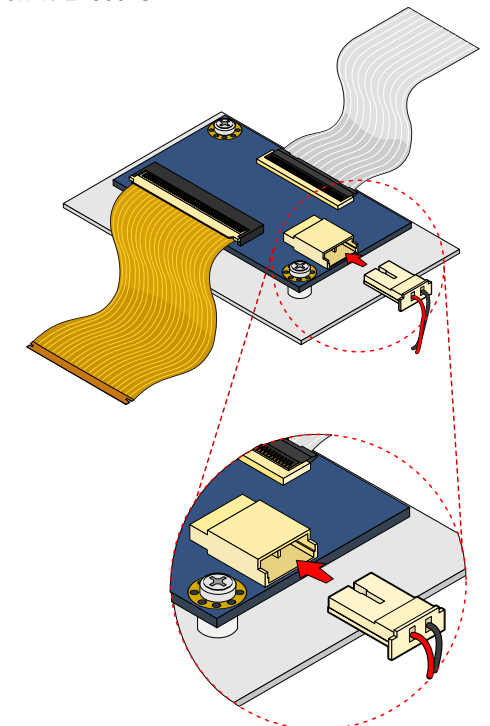

### Note:

Please boot up the system after confirming all the cables are firmly connected, otherwise it may damage the VAB-600 mainboard.

# 2 Connector Pinouts

CN2: Back Light connector

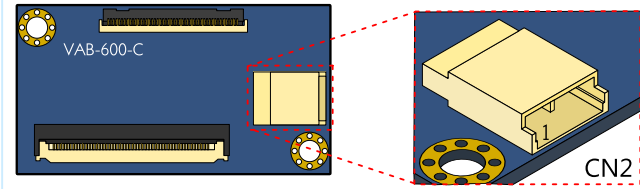

Pin	Signal
1	LED+
2	LED-
G1	GND
G2	GND

LCD1: TTL panel signal connector

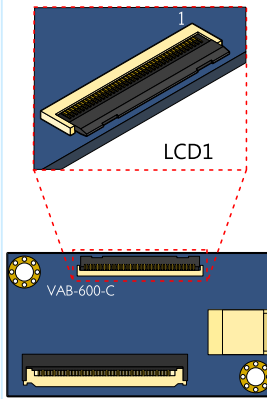

Pin	Signal	Pin	Signal
1	GND	21	GND
2	GND	22	LD02
3	DVP1CLK+	23	LD03
4	GND	24	LD04
5	GND	25	GND
6	LD18	26	LD05
7	LD19	27	LD06
8	LD20	28	LD07
9	GND	29	GND
10	LD21	30	GND
11	LD22	31	GND
12	LD23	32	DVPDE
13	GND	33	DVPVS
14	LD10	34	LCD_VDD(3.3V)
15	LD11	35	LCD_VDD(3.3V)
16	LD12	36	LCD_VDD(3.3V)
17	GND	37	LCD_VDD(3.3V)
18	LD13	38	DVPHS
19	LD14	39	GND
20	LD15	40	GND

CN1: DVO signal connector

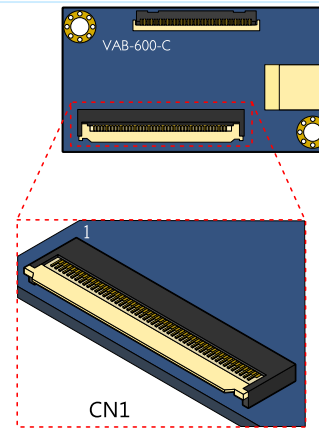

Pin	Signal	Pin	Signal	Pin	Signal	Pin	Signal
1	GND	14	DVP1CLK+	27	LD13	39	LD02
2	LVDSENVDD	15	GND	28	LD12	40	LD01
3	LVDSENBL	16	LD23	29	LD11	41	LD00
4	DVO_DATA	17	LD22	30	LD10	42	GND
5	DVO_CLK	18	LD21	31	LD09	43	VIN
6	I2C0SDA	19	LD20	32	LD08	44	VIN
7	I2C0SCL	20	LD19	33	GND	45	5VIN
8	TTL_RST-	21	LD18	34	LD07	46	5VIN
9	PWMOUT0	22	LD17	35	LD06	47	5VIN
10	DVPDE	23	LD16	36	LD05	48	VCC33
11	DVPVS	24	GND	37	LD04	49	VCC33
12	DVPHS	25	LD15	38	LD03	50	VCC33
13	GND	26	LD14				

For more information on this and other VIA products, please visit [www.viaembedded.com/en/](http://www.viaembedded.com/en/)

For further support and service, please visit [www.via.com.tw](http://www.via.com.tw)

**VIA Technologies, Inc.**

1F, 531, Zhong-zheng Road,  
Xindian District, New Taipei City 231,  
Taiwan

Tel: 886-2-2218-5452  
Fax: 886-2-2218-5453