



USER MANUAL

VIA SOM-3000

Starter Kit

Fanless low-power platform for

Edge AI applications with

MediaTek Genio 350 quad-core processor



Copyright

Copyright ©2022 VIA Technologies Incorporated. All rights reserved.

No part of this document may be reproduced, transmitted, transcribed, stored in a retrieval system, or translated into any language, in any form or by any means, electronic, mechanical, magnetic, optical, chemical, manual or otherwise without the prior written permission of VIA Technologies, Incorporated.

Trademarks

All trademarks are the property of their respective holders.

Disclaimer

No license is granted, implied or otherwise, under any patent or patent rights of VIA Technologies. VIA Technologies makes no warranties, implied or otherwise, in regard to this document and to the products described in this document. The information provided in this document is believed to be accurate and reliable as of the publication date of this document. However, VIA Technologies assumes no responsibility for the use or misuse of the information (including use or connection of extra device/equipment/add-on card) in this document and for any patent infringements that may arise from the use of this document. The information and product specifications within this document are subject to change at any time, without notice and without obligation to notify any person of such change.

VIA Technologies, Inc. reserves the right to make changes to the products described in this manual at any time without prior notice.

Regulatory Compliance

FCC-A Radio Frequency Interference Statement

This equipment has been tested and found to comply with the limits for a class A digital device, pursuant to part 15 of the FCC rules. These limits are designed to provide reasonable protection against harmful interference when the equipment is operated in a commercial environment. This equipment generates, uses, and can radiate radio frequency energy and, if not installed and used in accordance with the instruction manual, may cause harmful interference to radio communications. Operation of this equipment in a residential area is likely to cause harmful interference, in which case the user will be required to correct the interference at his personal expense.

Notice 1

The changes or modifications not expressly approved by the party responsible for compliance could void the user's authority to operate the equipment.

Notice 2

Shielded interface cables and A.C. power cord, if any, must be used in order to comply with the emission limits.

Notice 3

The product described in this document is designed for general use, VIA Technologies assumes no responsibility for the conflicts or damages arising from incompatibility of the product. Check compatibility issue with your local sales representatives before placing an order.



Tested To Comply
With FCC Standards
FOR HOME OR OFFICE USE

Battery Recycling and Disposal

- Only use the appropriate battery specified for this product.
- Do not re-use, recharge, or reheat an old battery.
- Do not attempt to force open the battery.
- Do not discard used batteries with regular trash.
- Discard used batteries according to local regulations.

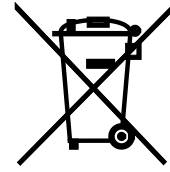

Safety Precautions

- Always read the safety instructions carefully.
- Keep this User's Manual for future reference.
- All cautions and warnings on the equipment should be noted.
- Keep this equipment away from humidity.
- Put this equipment on a reliable flat surface before setting it up.
- Check the voltage of the power source and adjust to 110/220V before connecting the equipment to the power inlet.
- Do not place the power cord where people will step on it.
- Always unplug the power cord before inserting any add-on card or module.
- If any of the following situations arise, get the equipment checked by authorized service personnel:
 - The power cord or plug is damaged.
 - Liquid has entered into the equipment.
 - The equipment has been exposed to moisture.
 - The equipment is faulty or you cannot get it work according to User's Manual.
 - The equipment has been dropped and damaged.
 - The equipment has an obvious sign of breakage.
- Do not leave this equipment in extreme temperatures or in a storage temperature above 60°C (140°F). The equipment may be damaged.
- Do not leave this equipment in direct sunlight.
- Never pour any liquid into the opening. Liquid can cause damage or electrical shock.
- Do not place anything over the power cord.
- Do not cover the ventilation holes. The openings on the enclosure protect the equipment from overheating.

Box Contents

Items for STK-SOM935-00A0

- 1 x VIA SOM-3000 module
- 1 x VIA VAB-935 carrier board
- 1 x 2.4G/5GHz antenna
- 1 x MIPI LCD + touch panel display
- 1 x 4-pin FFC cable
- 1 x Camera module
- 2 x 2W Speakers
- 1 x Microphone
- 1 x 3V, 240mAh RTC battery
- 1 x UART to USB debug board
- 1 x 12V 3A universal AC adapter

Ordering Information

Part Number	Description
10GPE20G10020A0	VIA SOM-3000 module with 2.0GHz MediaTek Genio 350 Quad-Core SoC, 16GB eMMC, 2GB LPDDR4 SDRAM, Wi-Fi 5, Bluetooth 5.0
STK-SOM935-00A0	VIA SOM-3000 Starter Kit with SOM-3000 Module + VAB-935 Carrier Board + Accessory Kit

Optional Accessories

Wireless Module Options	
Part Number	Description
EMIO-2575-00A0	Quectel EC25JFA 4G LTE mobile broadband miniPCIe module with two antennas and assembly (Japan only)

Table of Contents

1. Product Overview	1
1.1 Key Features.....	1
1.2 Product Specifications.....	1
1.3 Layout Diagram	4
2. On-Board I/O Connectors	5
2.1 UART Debug Connector	5
2.2 I-PEX Connector	6
3. Hardware Installation	7
3.1 Installing the VIA SOM-3000 Module on the Carrier Board.....	7
3.2 Connecting the Wi-Fi Antenna.....	8
4. Software and Technical Support	9
4.1 Android and Yocto Support.....	9
4.2 Technical Support and Assistance	9
Appendix A VIA VAB-935 Carrier Board Reference	10
A.1 Carrier Board I/O.....	10
A.2 Carrier Board Dimensions	11
A.3 Carrier Board Height Distribution	12
A.4 Carrier Board On-Board I/O	13
A.4.1 miniPCIe Slot.....	13
A.4.2 SIM Card Slot	14
A.4.3 Battery Charger Connector	15
A.4.4 RTC Battery Connector	16
A.4.5 Speaker Connectors	16
A.4.6 On-Board MIC Connector	17
A.4.7 MCU Upgrade Pin Header.....	18
A.4.8 MIPI CSI 4-Lane Connectors.....	18
A.4.9 Download Button & Pin	19
A.4.10 I/O Expansion Header	20
A.4.11 MIPI DSI 4-Lane Connector	21
A.4.12 Touch Panel Connector	22
A.4.13 M.2 Connectors	23
A.4.14 HDMI® Port	25
A.4.15 USB 2.0 Port	25
A.4.16 10/100Mbps Ethernet Port	26
A.4.17 COM Port	26
A.4.18 IR Receiver	27
A.4.19 DC Jack.....	27
A.4.20 Reset Button & Reset Pin	27
A.4.21 Micro USB 2.0 Port.....	28
A.4.22 Headphone Jack.....	28
A.4.23 Microphone Jack.....	28
A.4.24 Power Button	29
A.4.25 MicroSD Slot	29



- A.4.26 Power LED 30
- A.4.27 DIO Port 30
- Appendix B Installing PCIe Mini Card Accessories 31
 - B.1 Installing a PCIe Mini Card into the miniPCIe Slot 31
- Appendix C Connecting LCD Display 33
 - C.1 Connecting the TFT-LCD Display..... 33

List of Figures

Figure 01: VIA SOM-3000 module layout (top view)	4
Figure 02: Dimensions of the VIA SOM-3000 module (top view)	4
Figure 03: UART debug connector	5
Figure 04: I-PEX connector	6
Figure 05: VIA SOM-3000 module installation	7
Figure 06: Securing the VIA SOM-3000 module to the carrier board	7
Figure 07: Connecting the Wi-Fi antenna	8
Figure 08: VIA VAB-935 carrier board layout (top view)	10
Figure 09: VIA VAB-935 carrier board front panel I/O	10
Figure 10: VIA VAB-935 carrier board rear panel I/O	10
Figure 11: VIA VAB-935 carrier board layout (bottom view)	11
Figure 12: Dimensions of the VIA VAB-935 carrier board (top view)	11
Figure 13: External I/O dimensions of the VIA VAB-935 carrier board (front panel)	11
Figure 14: External I/O dimensions of the VIA VAB-935 carrier board (back panel)	12
Figure 15: Height distribution of the VIA VAB-935 carrier board (top view)	12
Figure 16: Height distribution of the VIA VAB-935 carrier board (bottom view)	12
Figure 17: miniPCIe slot	13
Figure 18: SIM card slot	14
Figure 19: Battery charger connector	15
Figure 20: RTC battery connector	16
Figure 21: Speaker connectors	16
Figure 22: On-board MIC connector	17
Figure 23: MCU upgrade pin header	18
Figure 24: MIPI CSI 4-lane connectors	18
Figure 25: Download button & pin	19
Figure 26: I/O expansion header	20
Figure 27: MIPI DSI 4-lane connector	21
Figure 28: Touch panel connector	22
Figure 29: M.2 connectors	23
Figure 30: M.2 connector placement - carrier board external I/O	24
Figure 31: HDMI port	25
Figure 32: USB 2.0 port	25
Figure 33: 10/100Mbps Ethernet port	26
Figure 34: COM port	26
Figure 35: IR receiver	27
Figure 36: DC jack	27
Figure 37: Reset button & pin	27
Figure 39: Headphone jack	28
Figure 40: Microphone jack	28
Figure 38: Micro USB 2.0 port	28
Figure 41: Power button	29
Figure 42: MicroSD card slot	29
Figure 44: DIO port	30
Figure 43: Power button	30
Figure 45: Installing a PCIe Mini Card	31
Figure 46: Securing the PCIe Mini Card	32
Figure 47: Connecting the 39-pin FFC cable of the TFT-LCD display to 'J7'	33
Figure 48: Connecting the 30-pin FFC cable of the Touch panel to 'J9'	33

List of Tables

Table 01: UART debug connector pinouts.....	5
Table 02: miniPCIe slot pinouts.....	13
Table 03: SIM card slot pinouts.....	14
Table 04: Battery charger connector pinouts.....	15
Table 05: RTC battery connector pinouts.....	16
Table 06: Speaker connector pinouts.....	17
Table 07: On-board MIC connector pinouts.....	17
Table 08: MCU upgrade pin header pinouts.....	18
Table 09: MIPI CSI 4-lane connectors pinouts.....	19
Table 10: I/O expansion header pinouts.....	20
Table 11: MIPI DSI 4-lane connector pinouts.....	21
Table 12: Touch panel connector pinouts.....	22
Table 13: M.2 connector pinouts.....	24
Table 14: HDMI port pinouts.....	25
Table 15: USB 2.0 port pinouts.....	25
Table 17: 10/100Mbps Ethernet port LED color definitions.....	26
Table 16: 10/100Mbps Ethernet port pinouts.....	26
Table 18: COM port pinouts.....	26
Table 19: Micro USB 2.0 port pinouts.....	28
Table 20: Power button behavior description.....	29
Table 21: MicroSD card slot pinouts.....	29
Table 23: DIO port pinouts.....	30
Table 22: Power LED behavior.....	30

1. Product Overview

Accelerate your time-to-market for groundbreaking Edge AI devices with the VIA SOM-3000 module. Powered by high performance, power-efficient MediaTek Genio 350 Edge AI platform, the board combines advanced AI technology for display, object recognition, and voice with rich wireless and I/O connectivity features.

The VIA SOM-3000's multimedia capabilities include hardware-accelerated H.265/H.264 Full HD video decoding and support for MIPI/HDMI/LVDS displays and cameras – making it the ideal solution for an unlimited array of home, commercial, industrial, and educational applications.

The VIA SOM-3000 harnesses the power of the MediaTek Genio 350 Edge AI platform to deliver blistering edge processing and multimedia performance. Besides quad-core ARM Cortex-A53 processors, the Genio 350 platform also features an integrated AI processor for deep learning, neural network acceleration, and computer vision applications, including facial recognition, object identification, and OCR.

Based on the 3.5" SBC 14.6cm x 10.2cm form factor, the VIA SOM-3000 offers a wealth of network connectivity options, including an integrated SIM card slot for LTE/4G, dual-band 802.11ac Wi-Fi, a 10/100Mbps Ethernet port, and Bluetooth 5.0. The board also features one USB 2.0 port and one Micro USB 2.0 OTG port, as well as HDMI, MIPI DSI display and MIPI CSI camera support with multi-function pins for I²C, SPI and GPIO connectivity. On-board storage is provided by 16GB eMMC 5.1 flash memory.

1.1 Key Features

- Compact 3.5" SBC form factor
- High-performance quad-core MediaTek Genio 350 processor
- Integrated AI processor for Edge AI applications
- Full HD hardware accelerated H.265/H.264 video decoding
- Dual-band 802.11a/b/g/n/ac Wi-Fi with Bluetooth 5.0, plus on-board SIM card slot
- 16GB onboard eMMC Flash memory
- MIPI DSI/HDMI/LVDS display, and MIPI CSI camera support
- Supports Android 12 and Yocto 3.1 operating systems
- Fanless and low power consumption

1.2 Product Specifications

Processor

- MediaTek Genio 350 Quad-Core Cortex A53 @ 2.0 GHz

System Memory

- 2GB LPDDR4 SDRAM

Storage

- 16GB EMMC5.1 Flash
- Micro SD Card Slot

Graphics

- ARM Mali-G52 3EE MC1 GPU
- 3D graphics accelerator capable of processing 1600M pixel/sec @ 800MHz
- OpenGL ES 1.1, 2.0, 3.2
- Vulkan1.0, 1.1

- OpenCL ES 2.0 full profile
- Supports Cadence Tensilica Vision P6 and HiFi4

Wireless Connectivity

- MediaTek MT6631
 - Dual band (2.4GHz & 5GHz) single stream Wi-Fi 802.11 a/b/g/n/ac RF
 - Bluetooth 5.0

Audio

- MediaTek MT6357/MT6390

HDMI

- Lontium LT8618SXB Digital Parallel Interface to HDMI 1.4 transmitter

USB

- Genesys GL852GT-MNG USB 2.0 MTT HUB

LAN

- Realtek RTL8152BNI-VB-CG USB2.0 to 10/100M Ethernet controller

Onboard I/O

- 2 x MIPI CSI 4-lane connectors (1st for front camera, 2nd for rear camera by ODM request)
- 1 x MIPI DSI 4-lane connector
- 1 x 30-pin capacitive touch panel connector
- 1 x RTC battery connector
- 1 x Battery charger connector
- 1 x miniPCIe slot for 4G with GNSS
- 1 x SIM card slot
- 1 x Download button
- 1 x MIC connector
- 2 x Speaker connectors
- 1 x MCU upgrade connector
- 1 x I/O expansion connector (supports GPIO x 5, I2C x1, UART x1, SPI x1, PWM x 2, ADC x 1 from SOM-3000, and GPIO x 11 from Expander IC)
- 2 x M.2 connectors for VIA SOM-3000 module

Front Panel I/O

- 1 x Micro USB 2.0 OTG port
- 1 x DIO port supporting 10 GPIO with 3.3V power
- 1 x Micro SD card slot
- 2 x Audio jacks: Line-out and Mic-in
- 1 x Power LED
- 1 x Power button

Back Panel I/O

- 1 x HDMI port
- 2 x USB 2.0 ports
- 1 x COM port for RS-232 (TX/RX)
- 1 x 10/100Mbps Ethernet port
- 1 x DC-in jack
- 1 x Reset button
- 1 x IR receiver

Power Supply

- 1 x 12V DC-in (supports 9V~15V)
- 1 x 2-cell 8.4V Li-on battery (optional)

Operating System

- Android 12
- Yocto 3.1

Operating Temperature

- 0°C ~ 60°C

Operating Humidity

- 0% ~ 95% (relative humidity ; non-condensing)

Form Factor

- 3.5" SBC, 14.6cm x 10.2cm (5.75" x 4.02")

Compliance

- CE, FCC, UKCA



Notes:

1. As the operating temperature provided in the specifications is a result of testing performed in a testing chamber, a number of variables can influence this result. Please note that the working temperature may vary depending on the actual situation and environment. It is highly recommended to execute a solid testing program and take all variables into consideration when building the system. Please ensure that the system is stable under the required operating temperature in terms of the target application.
2. Please note that the lifespan of the onboard eMMC memory chip may vary depending on the amount of access. More frequent and larger data access on the eMMC memory will shorten its lifespan. It is highly recommended to use a replaceable external storage (e.g., MicroSD card) for large data access.

1.3 Layout Diagram

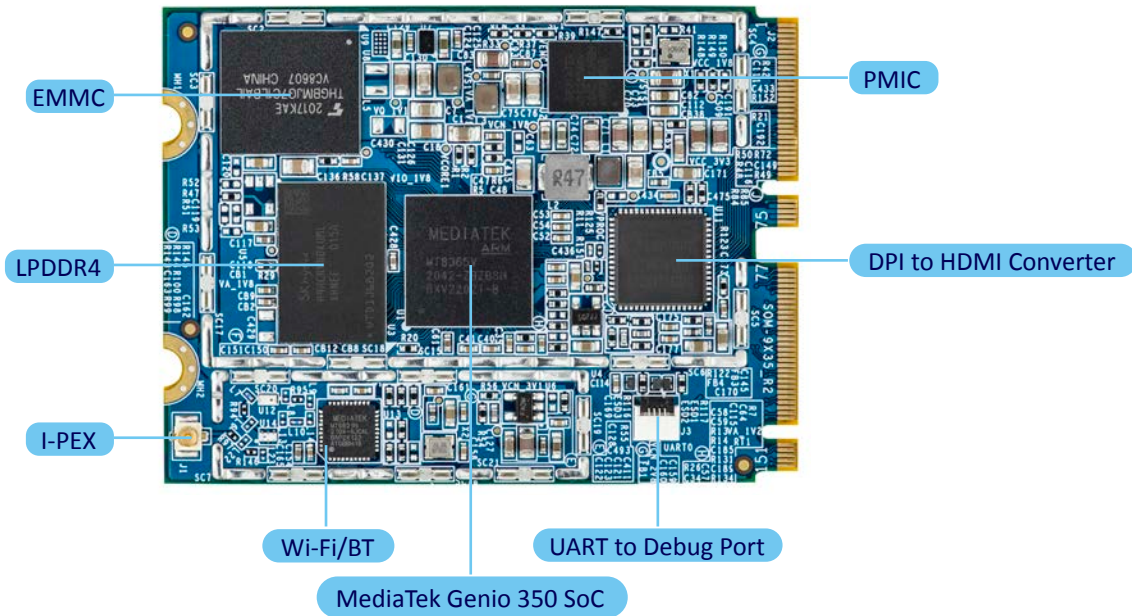

Figure 01: VIA SOM-3000 module layout (top view)

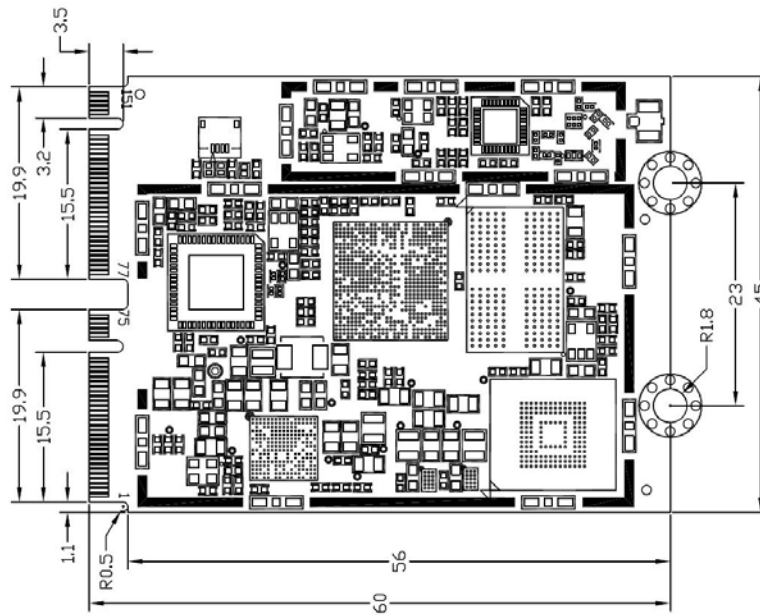

Figure 02: Dimensions of the VIA SOM-3000 module (top view)

2. On-Board I/O Connectors

This chapter provides information about the on-board connectors and pin headers of the VIA SOM-3000 module.

2.1 UART Debug Connector

The VIA SOM-3000 module is equipped with a UART debug connector labeled 'J3'. The pinouts of UART debug connector are shown below.

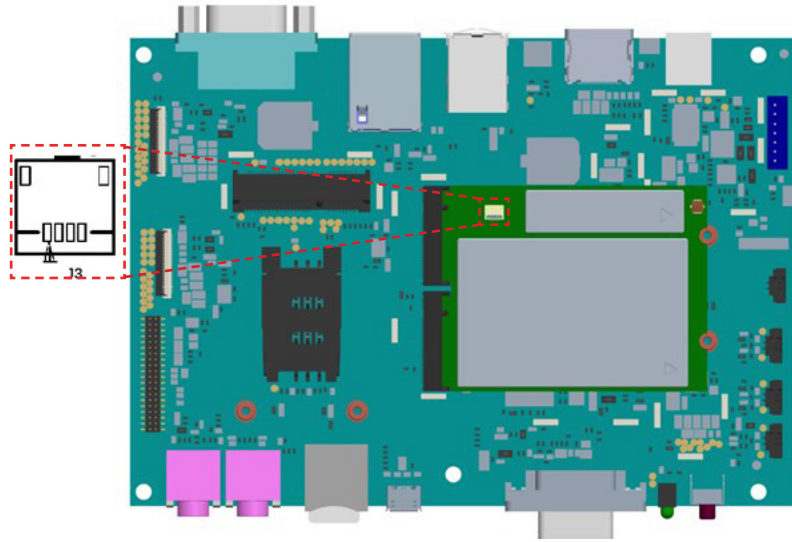

Figure 03: UART debug connector

J3	
Pin	Signal
1	GND
2	UTXD0
3	URXD0
4	VCC_1V8

Table 01: UART debug connector pinouts

2.2 I-PEX Connector

The VIA SOM-3000 comes with an I-PEX connector labeled 'J1' which is used for connecting the Bluetooth and Wi-Fi antenna. The diagram of the I-PEX connector is shown below.

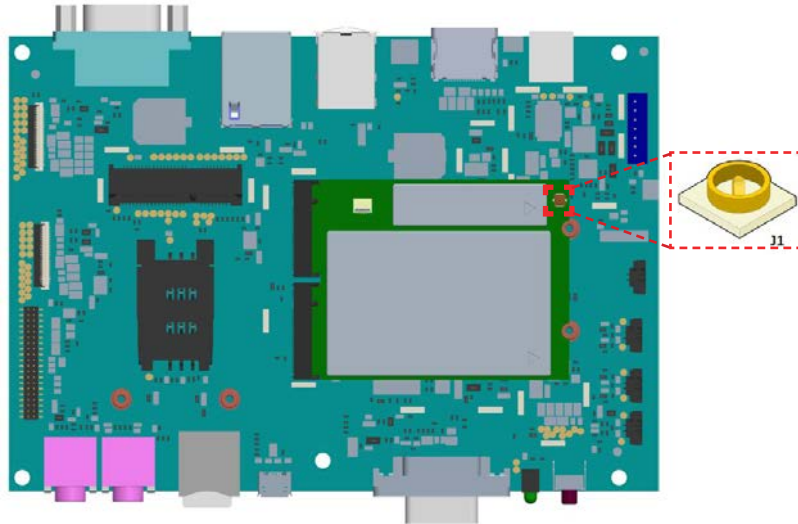

Figure 04: I-PEX connector

3. Hardware Installation

3.1 Installing the VIA SOM-3000 Module on the Carrier Board

Step 1

Align the VIA SOM-3000 module's notch with the notch of the M.2 slot located on the VIA VAB-935 carrier board's top side and insert the VIA SOM-3000 module at a 30° angle.

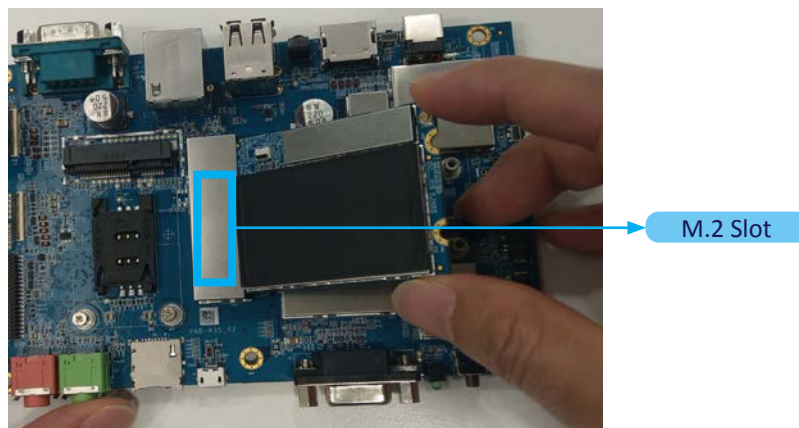

Figure 05: VIA SOM-3000 module installation

Step 2

Once the VIA SOM-3000 module has been fully inserted, gently push down the module until its standoff holes align with the carrier board's screw holes and secure the module with the two M2*4 mm screws provided.

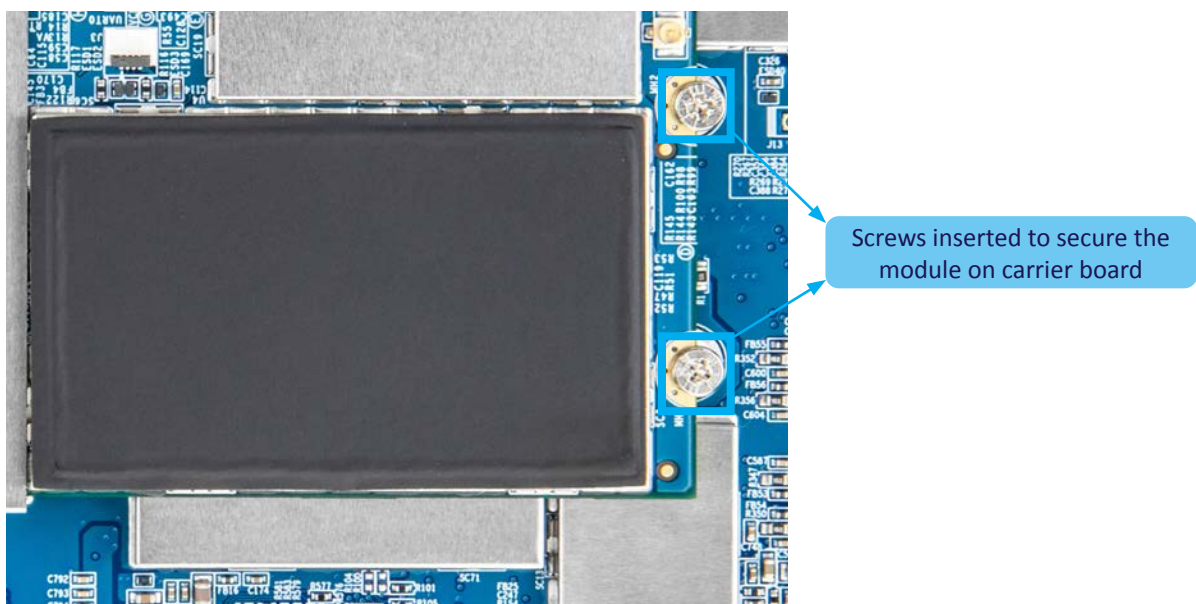

Figure 06: Securing the VIA SOM-3000 module to the carrier board

3.2 Connecting the Wi-Fi Antenna

Step 1

Connect the Wi-Fi Antenna to the I-PEX connector on the VIA SOM-3000 module.

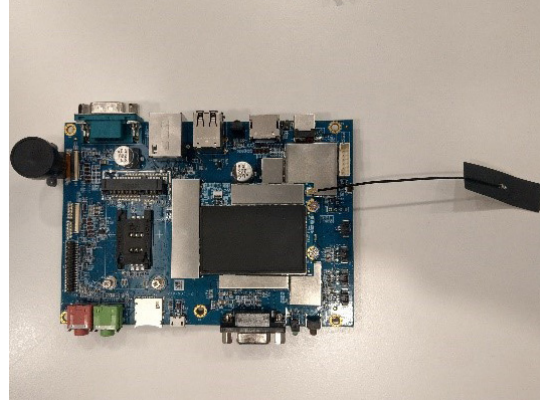
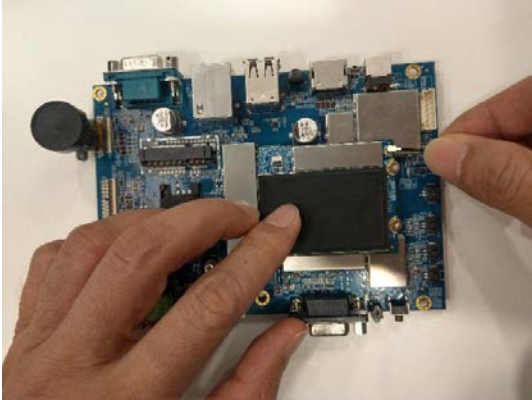

Figure 07: Connecting the Wi-Fi antenna

4. Software and Technical Support

4.1 Android and Yocto Support

The VIA SOM-3000 features a complete software evaluation image featuring the Android 12 and Yocto 3.1 operating systems.

4.2 Technical Support and Assistance

- For utilities downloads and the latest documentation and information about the VIA SOM-3000, please visit our website at <https://www.viatech.com/en/edge/som-3000/>.
- For technical support and additional assistance, always contact your local sales representative or board distributor, or go to <https://www.viatech.com/en/support/drivers/> for technical support.
- For OEM clients and system integrators developing a product for long-term production, other code and resources may also be made available. Please visit our website at <https://www.viatech.com/en/contact/> to submit a request.

Appendix A VIA VAB-935 Carrier Board Reference

A.1 Carrier Board I/O

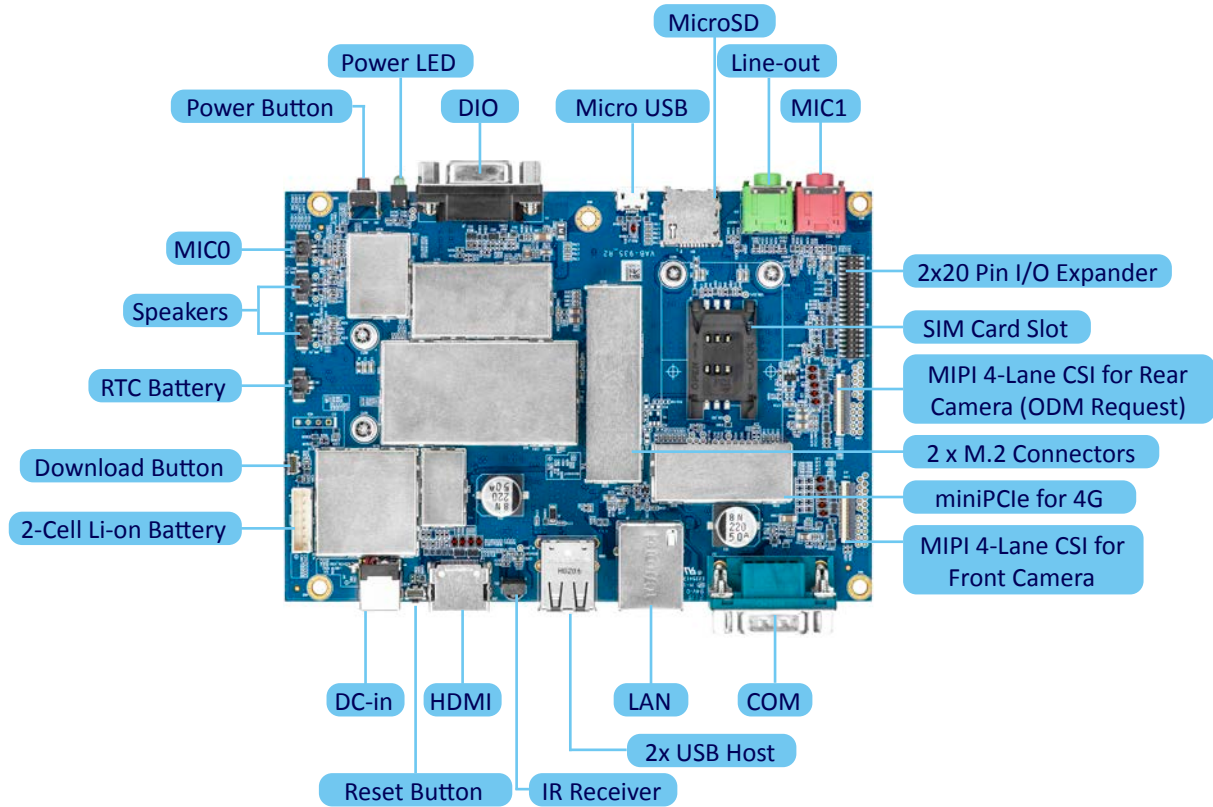

Figure 08: VIA VAB-935 carrier board layout (top view)

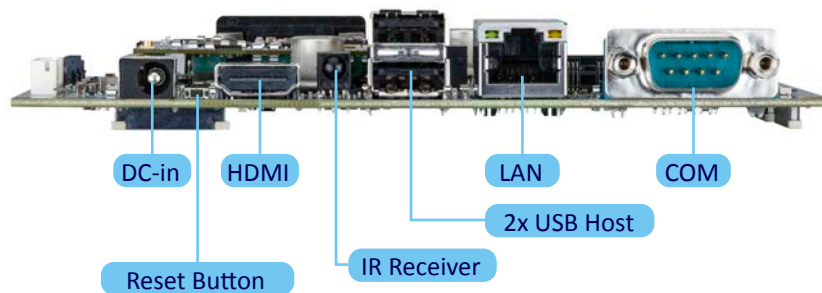

Figure 09: VIA VAB-935 carrier board front panel I/O



Figure 10: VIA VAB-935 carrier board rear panel I/O

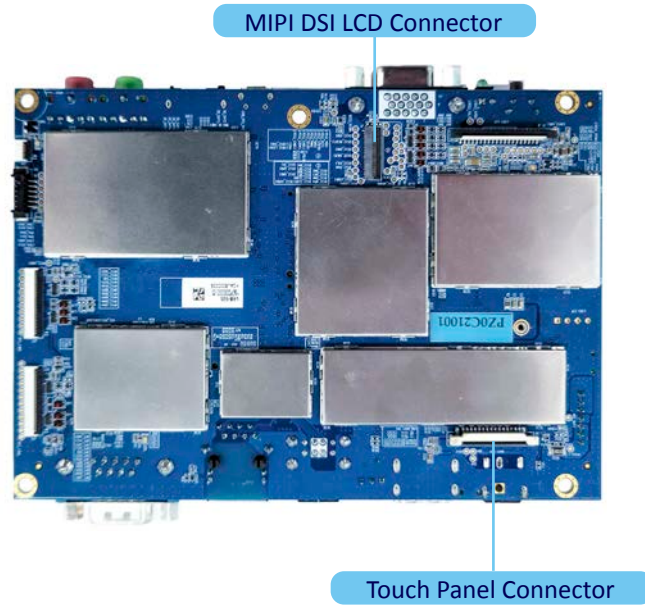

Figure 11: VIA VAB-935 carrier board layout (bottom view)

A.2 Carrier Board Dimensions

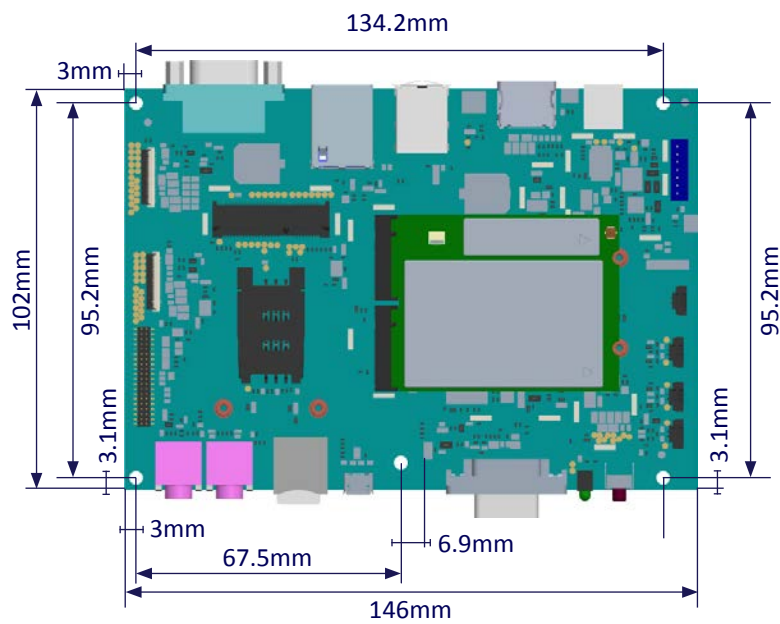

Figure 12: Dimensions of the VIA VAB-935 carrier board (top view)

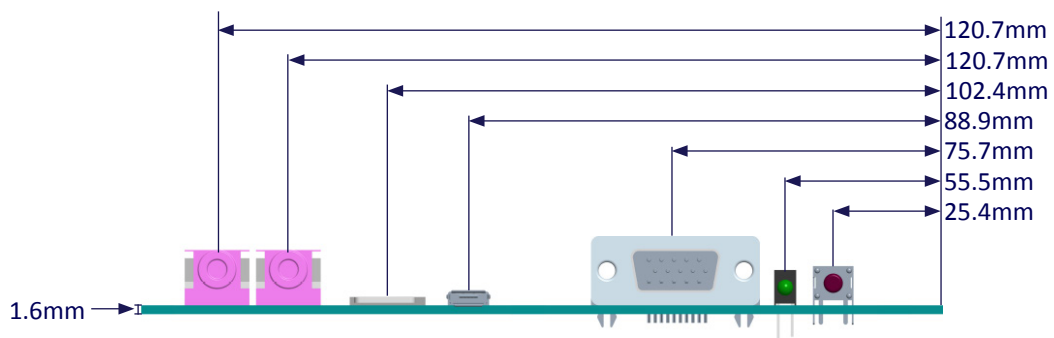

Figure 13: External I/O dimensions of the VIA VAB-935 carrier board (front panel)

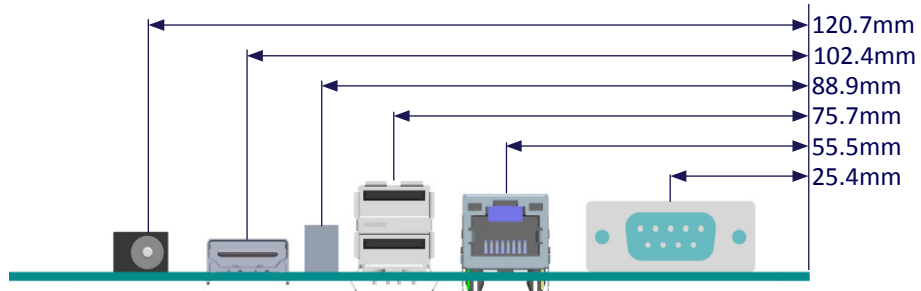

Figure 14: External I/O dimensions of the VIA VAB-935 carrier board (back panel)

A.3 Carrier Board Height Distribution

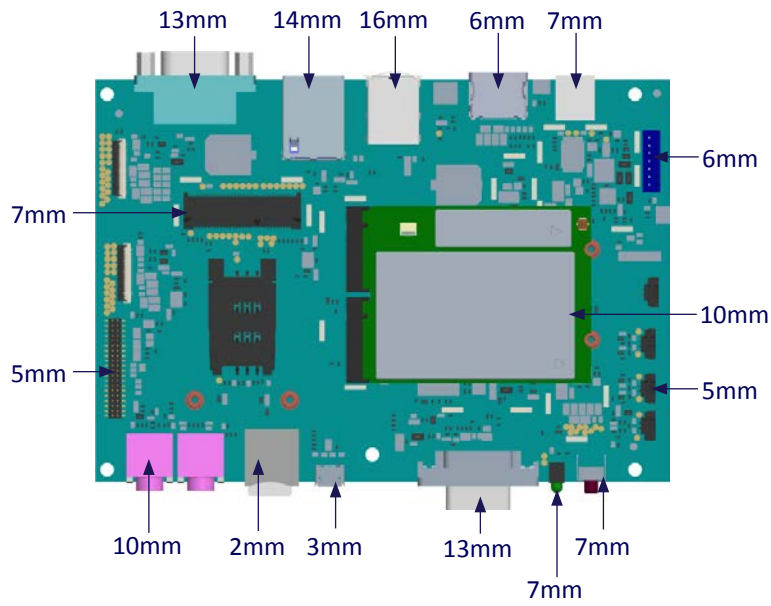

Figure 15: Height distribution of the VIA VAB-935 carrier board (top view)

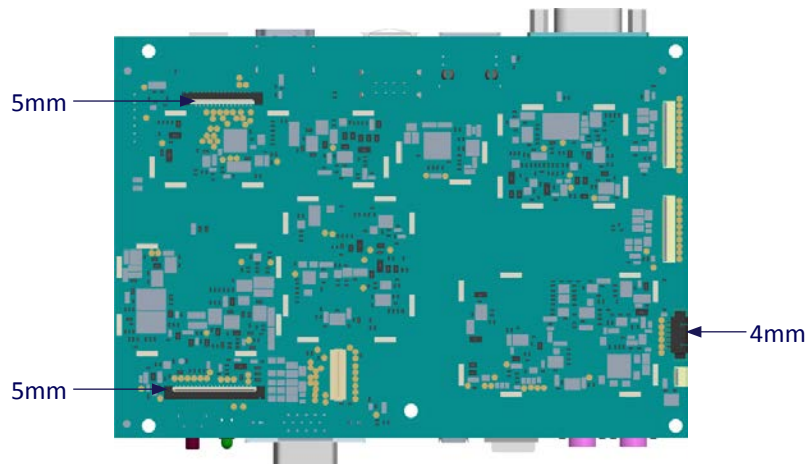

Figure 16: Height distribution of the VIA VAB-935 carrier board (bottom view)

A.4 Carrier Board On-Board I/O

A.4.1 miniPCIe Slot

The VIA VAB-935 carrier board is equipped with a miniPCIe slot labeled 'J3' for wireless networking options such as a 4G module (EC-20/EC-25). The pinouts of the miniPCIe slot are shown below.

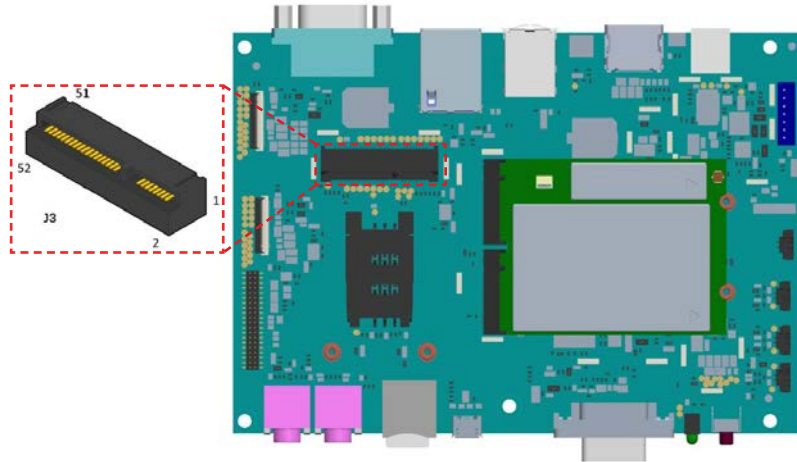

Figure 17: miniPCIe slot

Pin	Signal	Pin	Signal	Pin	Signal	Pin	Signal
1	Reserved	14	USIM_RST	27	GND	40	GND
2	VDD3V3_MPCIE	15	GND	28	Reserved	41	VDD3V3_MPCIE
3	Reserved	16	Reserved	29	GND	42	WWAN_LED-
4	GND	17	Reserved	30	Reserved	43	GND
5	Reserved	18	GND	31	Reserved	44	USIM_PRESENT
6	Reserved	19	Reserved	32	Reserved	45	Reserved
7	Reserved	20	MPCIE_W_DISABLE	33	MPCIE_RST_N	46	Reserved
8	USIM_VCC	21	GND	34	GND	47	Reserved
9	GND	22	MPCIE_RST_N	35	GND	48	VDD1V5
10	USIM_DATA	23	Reserved	36	MINI_PCIE_USB_DM	49	Reserved
11	Reserved	24	VDD3V3_MPCIE	37	GND	50	GND
12	USIM_CLK	25	Reserved	38	MINI_PCIE_USB_DP	51	Reserved
13	Reserved	26	GND	39	VDD3V3_MPCIE	52	VDD3V3_MPCIE

Table 02: miniPCIe slot pinouts

A.4.2 SIM Card Slot

The VIA VAB-935 carrier board comes with a SIM card slot that supports 4G SIM cards. SIM card usage requires that a 4G module is installed in the miniPCIe slot, otherwise the SIM card slot will be disabled. The SIM card slot is designed for use with 4G modules that do not support built-in SIM card slots. The pinouts of the SIM card slot are shown below.

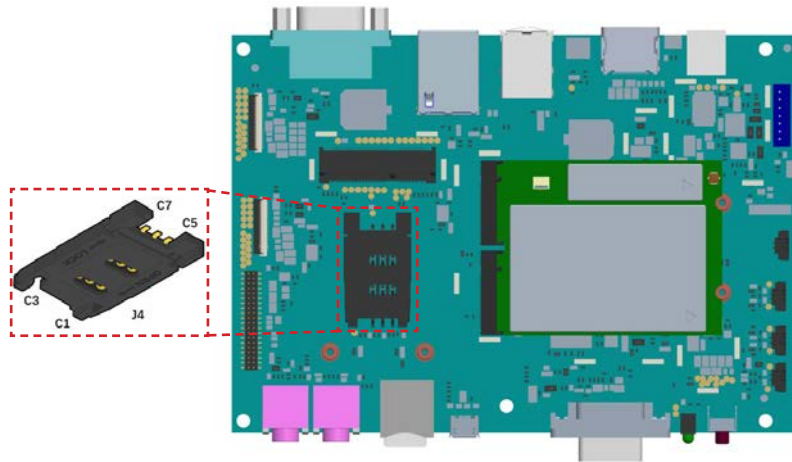

Figure 18: SIM card slot

Pin	Signal
C1	SIM_VCC
C2	SIM_RST
C3	SIM_CLK
C5	GND
C6	SIM_VPP
C7	SIM_DATA

Table 03: SIM card slot pinouts

A.4.3 Battery Charger Connector

The VIA VAB-935 carrier board is equipped with a battery charger connector labeled 'J17' which is used for charging the rechargeable lithium-ion polymer battery and powering the board. The pinouts of the battery charger connector are shown below.

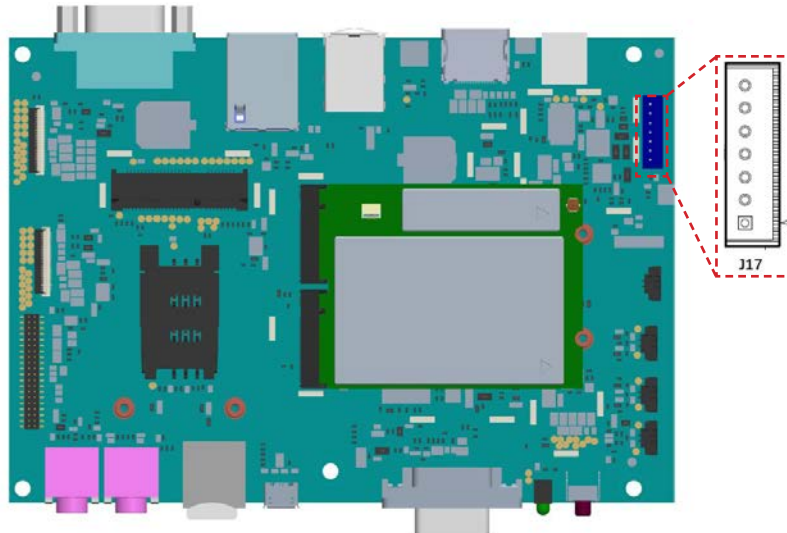

Figure 19: Battery charger connector

Pin	Signal
1	BAT+
2	BAT+
3	BAT+
4	TH
5	BAT-
6	BAT-
7	BAT-

Table 04: Battery charger connector pinouts

A.4.4 RTC Battery Connector

The VIA VAB-935 carrier board comes with an RTC battery connector labeled 'BAT1', and supports 3.0V 240mAh dioxide lithium batteries. It provides power to the MCU to maintain the real time clock while the DC adapter and lithium-ion polymer battery are both absent. The pinouts of the RTC battery connector are shown below.

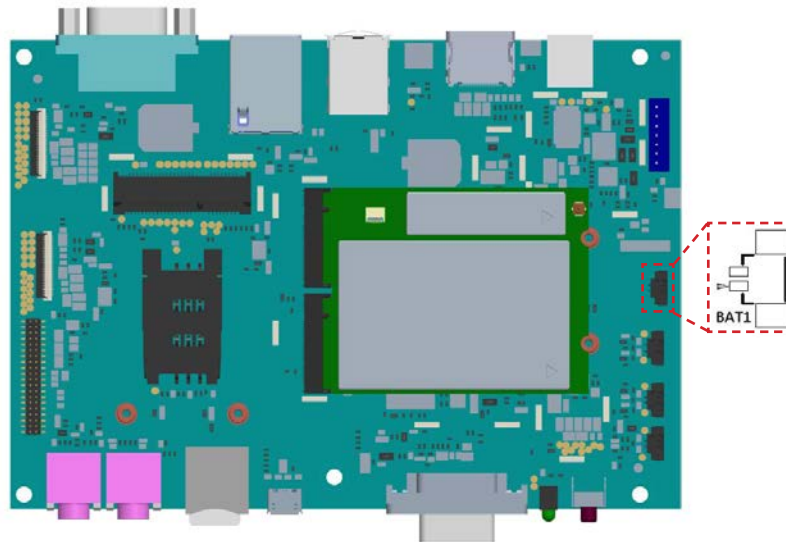

Figure 20: RTC battery connector

Pin	Signal
1	BAT_RTC
2	GND

Table 05: RTC battery connector pinouts

A.4.5 Speaker Connectors

The VIA VAB-935 carrier board is equipped with two mono speaker-out connectors labeled 'J22', 'J23' which are used for connecting the mono speakers. The pinouts of the speaker connectors are shown below.

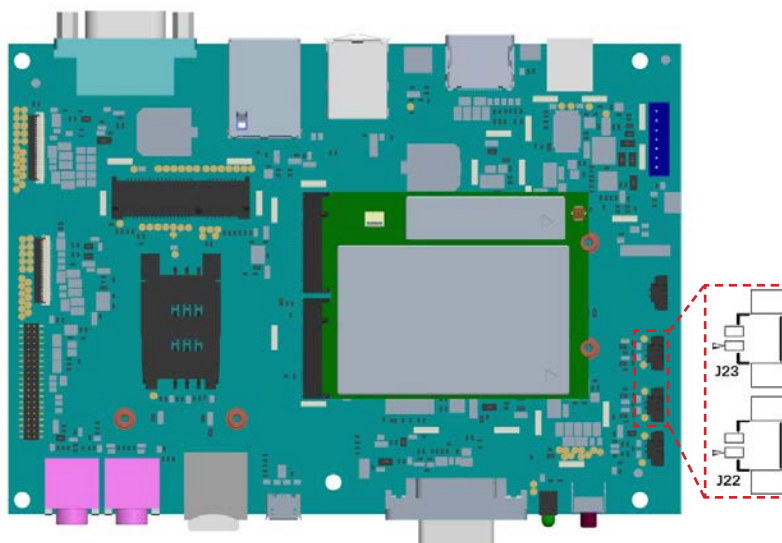

Figure 21: Speaker connectors

J22		J23	
Pin	Signal	Pin	Signal
1	SPK_LN	1	SPK_RN
2	SPK_LP	2	SPK_RP

Table 06: Speaker connector pinouts

A.4.6 On-Board MIC Connector

The VIA VAB-935 carrier board is equipped with an on-board MIC connector labeled 'J20' which is used for collecting the peripheral audio signal. The pinouts of the on-board MIC connector are shown below.

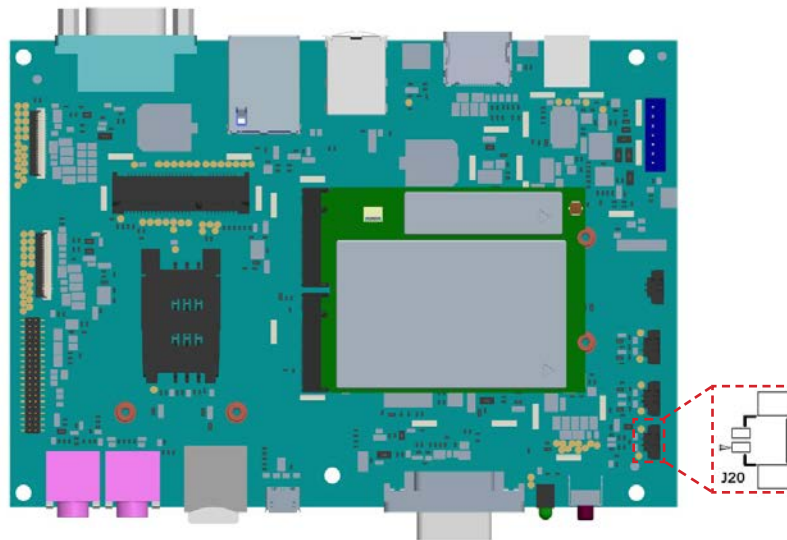

Figure 22: On-board MIC connector

Pin	Signal
1	MICO_N
2	MICO_P

Table 07: On-board MIC connector pinouts

A.4.7 MCU Upgrade Pin Header

The VIA VAB-935 carrier board is equipped with an MCU upgrade pin header which is used for flashing the MCU firmware on the management IC. The MCU upgrade pin header is labeled as 'J13'. The pinouts of the MCU upgrade pin header are shown below.

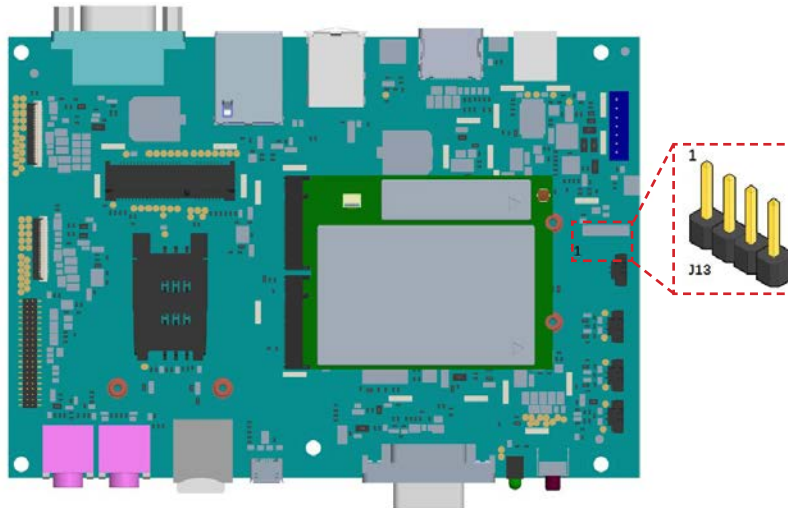

Figure 23: MCU upgrade pin header

Pin	Signal
1	VCC_RTC_1V8
2	STM_SWIM
3	GND
4	STM_RESET

Table 08: MCU upgrade pin header pinouts



Note:
Before flashing the MCU, the 12V DC power should be supplied by an adaptor to the DC-in Jack.

A.4.8 MIPI CSI 4-Lane Connectors

The VIA VAB-935 carrier board is equipped with two MIPI CSI 4-lane connectors labeled 'J15', 'J26'. The 'J15' is used for connecting the front camera while 'J26' is used for connecting the rear camera (ODM request). The pinouts of the MIPI CSI 4-lane connectors are shown below.

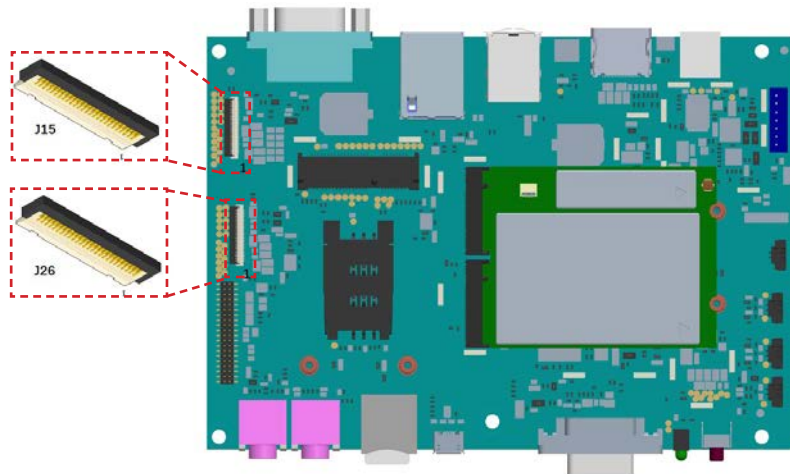

Figure 24: MIPI CSI 4-lane connectors

J15				J26			
Pin	Signal	Pin	Signal	Pin	Signal	Pin	Signal
1	RDN3	14	RDP0	1	RDN3	14	RDP0
2	RDP3	15	GND	2	RDP3	15	GND
3	GND	16	DOVDD_1.8V	3	GND	16	DOVDD_1.8V
4	RDN2	17	AVDD_2.7V	4	RDN2	17	AVDD_2.7V
5	RDP2	18	NC	5	RDP2	18	NC
6	GND	19	DVDD_1.05V	6	GND	19	DVDD_1.05V
7	CLKN	20	NC	7	CLKN	20	NC
8	CLKP	21	I2C_DATA	8	CLKP	21	I2C_DATA
9	GND	22	I2C_CLK	9	GND	22	I2C_CLK
10	RDN1	23	GND	10	RDN1	23	GND
11	RDP1	24	CLK of sensor	11	RDP1	24	CLK of sensor
12	GND	25	Power down N	12	GND	25	Power down N
13	RDN0	26	Reset	13	RDN0	26	Reset

Table 09: MIPI CSI 4-lane connectors pinouts



Note:
The MIPI CSI 4-lane connectors are bottom contact type.

A.4.9 Download Button & Pin

The VIA VAB-935 carrier board comes with a download button, and a download pin which is contained within the DIO connector. These are used to enter the firmware download mode. The download button is labeled as 'SW6' and the download pin in DIO connector 'J11' is pin-9.

To enter the firmware download mode, connect the USB OTG to a PC, press the button 'SW6', or short 'J11' pin-8 & pin-9, then press the power button for more than 2 seconds. The diagram of the download button and download pin in DIO connector J11 are shown below.

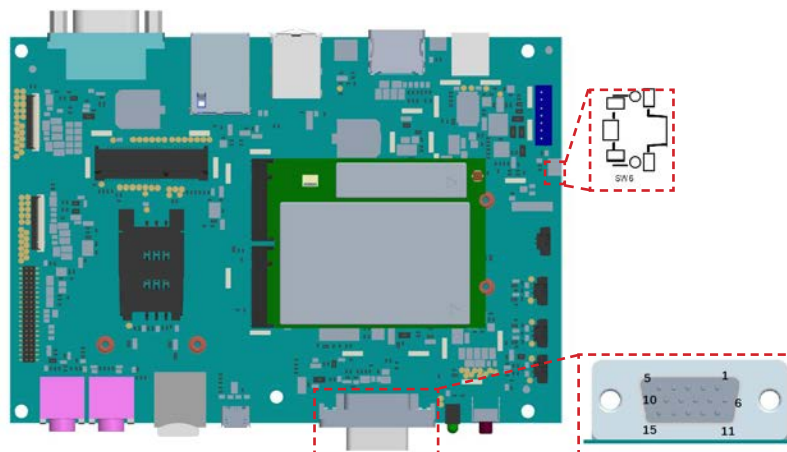

Figure 25: Download button & pin

A.4.10 I/O Expansion Header

The VIA VAB-935 carrier board comes with an I/O expansion header labeled as 'J24' which is used for connecting the I²C, SPI, UART, PWM, ADC, and 5 CPU GPIO +11 I/O expander GPIO devices. The I/O expansion header is compatible with the Raspberry Pi 40-pin connector. The pinouts of the I/O expansion pin header are shown below.

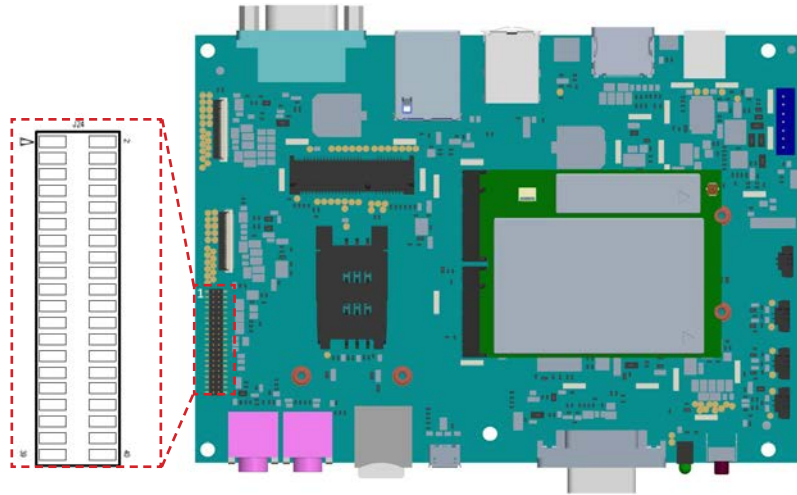

Figure 26: I/O expansion header

Pin	Signal	Pin	Signal	Pin	Signal	Pin	Signal
1	3V3_VCC	2	5V0_VCC	21	SPI_MISO	22	CPU_EXT_GPIO2
3	I2C0_SDA	4	5V0_VCC	23	SPI_CLK	24	SPI_XCS
5	I2C0_SCL	6	GND	25	GND	26	NC
7	CPU_EXT_INT2	8	UART2_TXD	27	RPI_GPIO13	28	RPI_GPIO11
9	GND	10	UART2_RXD	29	RPI_GPIO10	30	GND
11	RPI_GPIO2	12	RPI_GPIO3	31	RPI_GPIO12	32	PWM0
13	ADC2_RPI	14	GND	33	PWM1	34	GND
15	CPU_EXT_INT1	16	CPU_EXT_GPIO1	35	RPI_GPIO15	36	RPI_GPIO14
17	3V3_VCC	18	CPU_EXT_GPIO3	37	RPI_GPIO17	38	RPI_GPIO16
19	SPI_MOSI	20	GND	39	GND	40	RPI_GPIO18

Table 10: I/O expansion header pinouts



Note:

The standard EVK and BSP software only supports the GPIO feature for the I/O expansion header. Other features can be supported by request only.

A.4.11 MIPI DSI 4-Lane Connector

The VIA VAB-935 carrier board is equipped with a MIPI DSI 4-lane connector labeled 'J7' which is used for connecting the MIPI LCD display. 'J7' is placed on the bottom layer of the carrier board. The pinouts of the MIPI DSI connector are shown below.

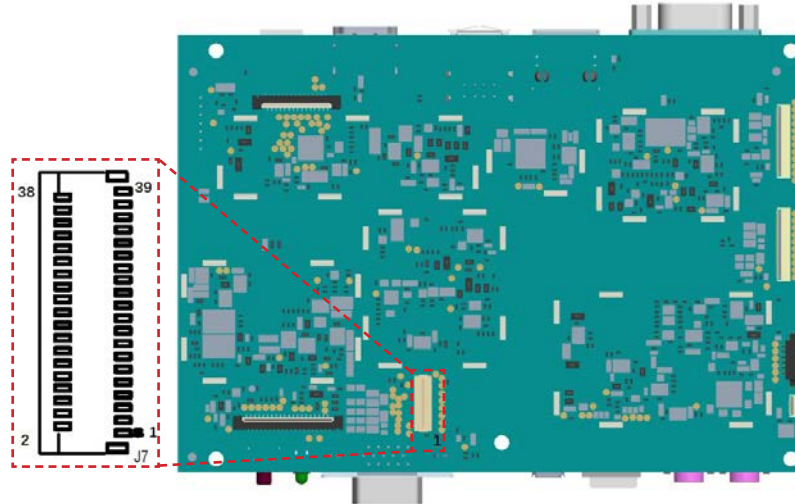

Figure 27: MIPI DSI 4-lane connector

Pin	Signal	Pin	Signal	Pin	Signal	Pin	Signal
1	VCOM_3.15V	2	VDDIO_1.8V	21	NC	22	MIPI_CLKP
3	VDDIO_1.8V	4	ID	23	GND	24	MIPI_D3N
5	RESET	6	STBYB	25	NC	26	MIPI_D3P
7	GND	8	MIPI_D0N	27	GND	28	NC
9	NC	10	MIPI_D0P	29	NC	30	AVDD_9.6V
11	GND	12	MIPI_D1N	31	SHLR	32	UPDN
13	NC	14	MIPI_D1P	33	VGL_-6V	34	GND
15	GND	16	MIPI_D2N	35	VGH_18V	36	LEDK
17	NC	18	MIPI_D2P	37	LEDK	38	LEDA
19	GND	20	MIPI_CLKN	39	LEDA		

Table 11: MIPI DSI 4-lane connector pinouts



Note:

The MIPI DSI 4-lane connector is a top contact type.

A.4.12 Touch Panel Connector

The VIA VAB-935 carrier board is equipped with a touch panel connector labeled 'J9' which is used to connect the Touch panel. The pinouts of the touch panel connector are shown below.

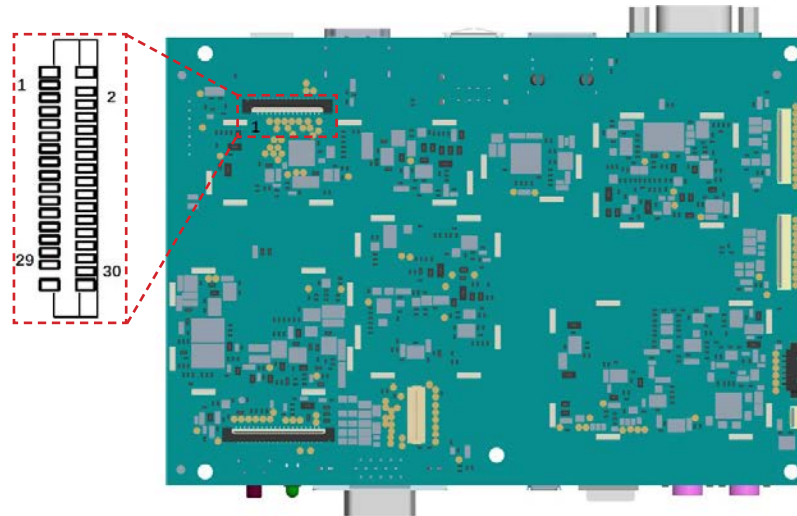

Figure 28: Touch panel connector

Pin	Signal	Pin	Signal	Pin	Signal	Pin	Signal
1	GND	2	SENSE09	17	DRIVE12	18	DRIVE11
3	SENSE08	4	SENSE07	19	DRIVE10	20	DRIVE09
5	SENSE06	6	SENSE05	21	DRIVE08	22	DRIVE07
7	SENSE04	8	SENSE03	23	DRIVE06	24	DRIVE05
9	SENSE02	10	SENSE01	25	DRIVE04	26	DRIVE03
11	SENSE00	12	GND	27	DRIVE02	28	DRIVE01
13	GND	14	GND	29	DRIVE00	30	GND
15	DRIVE14	16	DRIVE13				

Table 12: Touch panel connector pinouts



Note:

The touch panel FFC cable's golden finger faces inward to the carrier board.

A.4.13 M.2 Connectors

A.4.13.1 M.2 Connectors Pinouts

The VIA VAB-935 carrier board comes with two M.2 connectors labeled 'J1' and 'J2'. The M.2 connectors are used for connecting the VIA SOM-3000 module. The pinouts of the M.2 connectors are shown below.

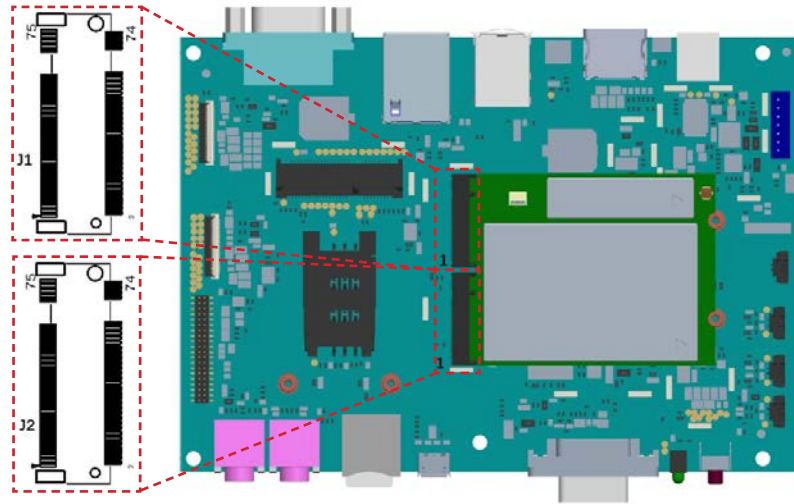

Figure 29: M.2 connectors

J1				J2			
1	HDMI_TX_CEC	2	VIN_DC	1	USB_P1_DM	2	AU_VIN1_N
3	HDMI_TX_DDCSCL	4	HDMI_TX_HPD	3	USB_P1_DP	4	AU_VIN1_P
5	HDMI_TX_DDCSDA	6	SD_WP	5	GND	6	ACCDET
7	I2C2_SDA	8	MSDC1_INSI	7	USB_P0_DM	8	AU_VIN0_N
9	I2C2_SCL	10	MSDC1_DAT1	9	USB_P0_DP	10	AU_VIN0_P
11	GND	12	MSDC1_DAT0	11	GND	12	AVSS28_AUD
13	CSI1B_L1N	14	GND	13	USBOTG_VBUS	14	AU_HP_RIGHT
15	CSI1B_L1P	16	MSDC1_CLK	15	USBOTG_ID	16	AU_HP_LEFT
17	CSI1B_L0N	18	MSDC1_CMD	17	USBOTG_DRVVBUS	18	GND
19	CSI1B_L0P	20	MSDC1_DAT3	19	GND	20	EXT_GPIO3
21	GND	22	MSDC1_DAT2	21	Gas Gauge CS_N	22	EXT_GPIO2
23	CSI1A_L2N	24	I2C1_SCL	23	Gas Gauge CS_P	24	EXT_GPIO1
25	CSI1A_L2P	26	I2C1_SDA	25	Gas Gauge BATSNS	26	SPI_CS
27	GND	28	GPIO_CTP_RST	27	I2C0_SDA	28	SPI_MOSI
29	CSI1A_L1N	30	ENIT_CTP_INT	29	I2C0_SCL	30	SPI_MISO
31	CSI1A_L1P	32	GND	31	EXT_INT3	32	SPI_CLK
33	CSI1A_L0N	34	DSI_D3_P	33	EXT_INT2	34	GND
35	CSI1A_L0P	36	DSI_D3_N	35	EXT_INT1	36	UART2_RXD
37	GND	38	DSI_D1_P	37	GND	38	UART2_TXD
39	CSI0B_L2N	40	DSI_D1_N	39	TX_CH2_P	40	UART1_TXD
41	CSI0B_L2P	42	GND	41	TX_CH2_M	42	UART1_RXD
43	CSI0B_L0N	44	DSI_CLK_P	43	TX_CH1_P	44	MCU_INT

J1				J2			
45	CSI0B_L0P	46	DSI_CLK_N	45	TX_CH1_M	46	MCU_WDI
47	GND	48	GND	47	GND	48	SYSRSTB
49	CSI0B_L1N	50	DSI_D2_N	49	TX_CH0_P	50	MCU_STATUS
51	CSI0B_L1P	52	DSI_D2_P	51	TX_CH0_M	52	KPCOLO
53	GND	54	DSI_D0_N	53	GND	54	EXT_3V3_ENABLE
55	CSI0A_L0N	56	DSI_D0_P	55	TX_CLK_P	56	EXT_PMIC_EN1
57	CSI0A_L0P	58	GND	57	TX_CLK_M	58	PWM_A
67	CSI0A_L1N	68	LCM_ENN	67	ADC_VIN0	68	PWM_C
69	CSI0A_L1P	70	LCM_ENP	69	GND	70	GND
71	GND	72	LCM_RST	71	VSYS	72	VSYS
73	CSI0A_L2N	74	DISP_PWM	73	GND	74	GND
75	CSI0A_L2P			75	VSYS		

Table 13: M.2 connector pinouts

A.4.13.2 M.2 Connectors Placement

The following figure shows the placement of the board-to-board M.2 connectors on the VIA VAB-935 carrier board.

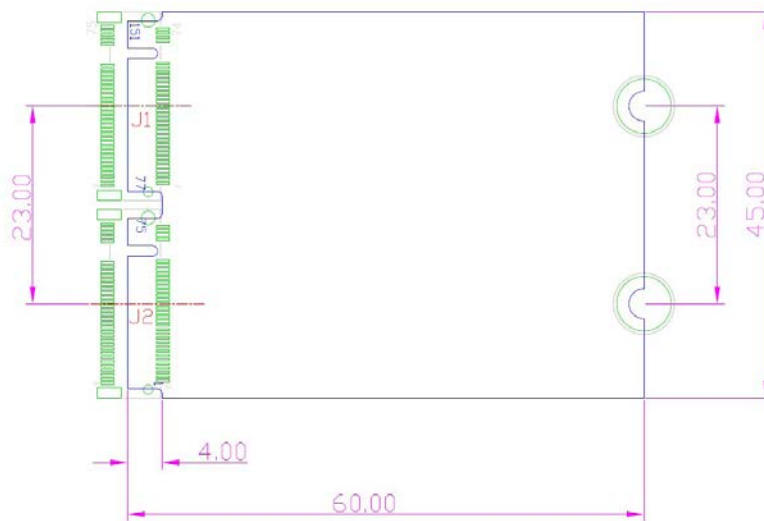

Figure 30: M.2 connector placement - carrier board external I/O

The VIA VAB-935 carrier board has a wide selection of interfaces, and includes a selection of frequently-used ports as part of the external I/O coastline.

A.4.14 HDMI® Port

The VIA VAB-935 carrier board is equipped with one HDMI port on the back panel. The HDMI port Type-A receptacle connector provides connection to High Definition video and digital audio using a single cable. The pinouts of the HDMI port are shown below.

Pin	Signal	Pin	Signal
1	D2+	11	GND
2	GND	12	CLK-
3	D2-	13	CEC
4	D1+	14	NC
5	GND	15	DDC_CLK
6	D1-	16	DDC_DATA
7	D0+	17	GND
8	GND	18	HDMI_5V
9	D0-	19	PLUG_DET
10	CLK+		

Table 14: HDMI port pinouts



Figure 31: HDMI port

A.4.15 USB 2.0 Port

The VIA VAB-935 carrier board is equipped with two USB 2.0 ports on the back panel. The USB 2.0 ports provide complete Plug and Play and hot swap capabilities for external devices. The pinouts of the USB 2.0 ports are shown below.

Pin	Signal
1	VCC
2	USB data -
3	USB data+
4	GND

Table 15: USB 2.0 port pinouts



Figure 32: USB 2.0 port

A.4.16 10/100Mbps Ethernet Port

The VIA VAB-935 carrier board comes with a 10/100Mbps Ethernet port on the back panel which uses an 8 Position and 8 Contact (8P8C) receptacle connector commonly known as RJ-45. It is fully compliant with the IEEE 802.3 (10BASE-T) and 802.3u (100BASE-TX) standards. The pinouts of the 10/100Mbps Ethernet port are shown below.

LAN	
Pin	Signal
1	TD+
2	TD-
3	RD+
4	NC
5	NC
6	RD-
7	NC
8	NC

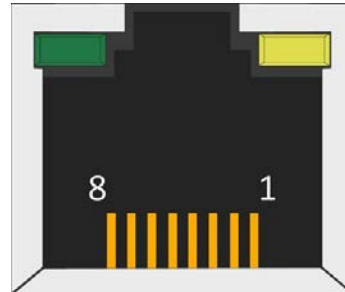

Figure 33: 10/100Mbps Ethernet port

Table 16: 10/100Mbps Ethernet port pinouts

The 10/100Mbps Ethernet port has two individual LED indicators located on the front side to show its Active/Link and Speed status.

	Link LED (Left LED on RJ-45 port)	Active LED (Right LED on RJ-45 port)
Link off	LED is off	LED is off
Speed_10Mbit	LED is off	Orange flash
Speed_100Mbit	Green is on	Orange flash

Table 17: 10/100Mbps Ethernet port LED color definitions

A.4.17 COM Port

The VIA VAB-935 carrier board is equipped with a COM (RS-232) port on the back panel. The COM port supports RS-232 (TX/RX) mode and is used to control peripheral equipment. The pinouts of the COM port are shown below.

Pin	Signal	Pin	Signal
1	NC	6	NC
2	RXD	7	NC -
3	TXD	8	NC
4	NC	9	MCU_RESET
5	GND		

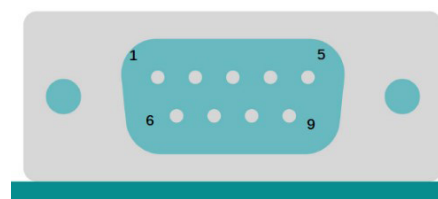

Figure 34: COM port

Table 18: COM port pinouts

A.4.18 IR Receiver

The VIA VAB-935 carrier board comes with an IR receiver located on the rear I/O panel. The IR receiver is used for receiving IR signals from infrared remote controllers. The diagram of the IR receiver is shown below.



Figure 35: IR receiver

A.4.19 DC Jack

The VIA VAB-935 carrier board comes with a DC Jack located on the rear I/O panel. The DC Jack is used for supplying 12V-DC power from a compliant adapter. The diagram of the DC Jack is shown below.

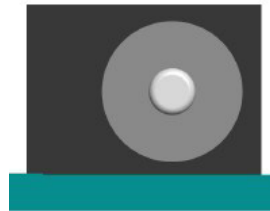

Figure 36: DC jack

A.4.20 Reset Button & Reset Pin

The VIA VAB-935 carrier board comes with a reset button on the back I/O panel labeled 'SW3', which allows users to reboot or reset the system forcibly. The VIA VAB-935 carrier board also comes with an MCU reset pin located in the COM connector 'J12' pin-9. The system will power down when the 'J12' pin-5 & pin-9 are shorted. The diagram of the reset button and reset pin are shown below.

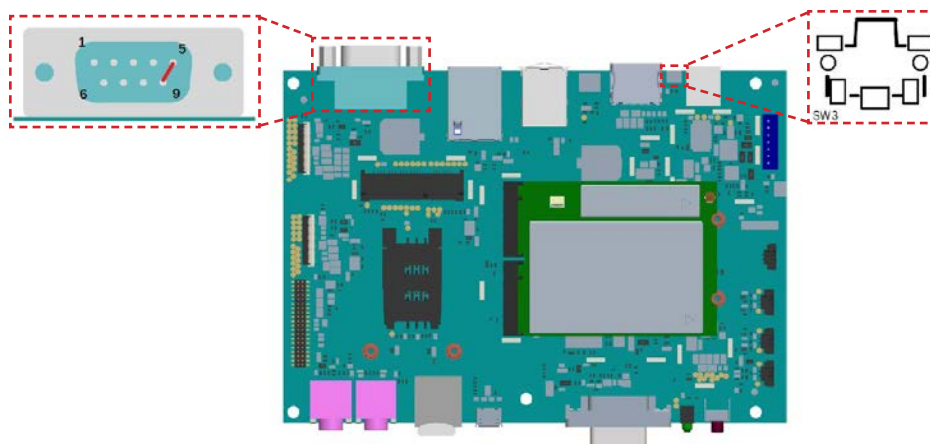

Figure 37: Reset button & pin

A.4.21 Micro USB 2.0 Port

The VIA VAB-935 carrier board is equipped with a Micro USB 2.0 port on the front panel. The Micro USB 2.0 port is used for downloading the OS image. The pinouts of the Micro USB 2.0 port are shown below.

Pin	Signal
1	VBUS
2	D-
3	D+
4	ID
5	GND



Figure 38: Micro USB 2.0 port

Table 19: Micro USB 2.0 port pinouts

A.4.22 Headphone Jack

The VIA VAB-935 carrier board comes with a 3.5mm headphone jack located on the front side panel. The headphone jack is used for connecting to external speakers or headphones. The diagram of the headphone jack is shown below.



Figure 39: Headphone jack

A.4.23 Microphone Jack

The VIA VAB-935 carrier board comes with a 3.5mm microphone jack located on the front I/O panel. The microphone jack is used for connecting to external microphones. The diagram of the microphone jack is shown below.

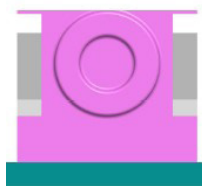

Figure 40: Microphone jack

A.4.24 Power Button

The VIA VAB-935 carrier board comes with a power button located on the front I/O panel. The power button can support two functions: Power On/Off and System Suspend/Resume. The diagram of the power button is shown below.

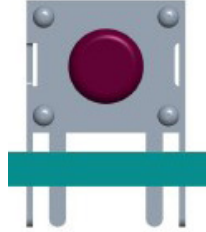

Figure 41: Power button

Power Button Behavior	
Power On/Off	Press and hold the button for more than 2 seconds to power on. To power off, press and hold the button for more than 4 seconds.
System Suspend/Resume	Quickly press the power button once to suspend the system. While in suspend mode, quickly press the button once to resume.

Table 20: Power button behavior description

A.4.25 MicroSD Slot

The VIA VAB-935 carrier board is equipped with a MicroSD Slot on the front I/O panel. The MicroSD Slot is used for storage data, pictures, video, audio, documents and so on. The pinouts of the MicroSD Slot are shown below.

Pin	Signal
1	DAT2
2	DAT3
3	CMD
4	VCC
5	CLK
6	GND
7	DAT0
8	DAT1
9	Card detect

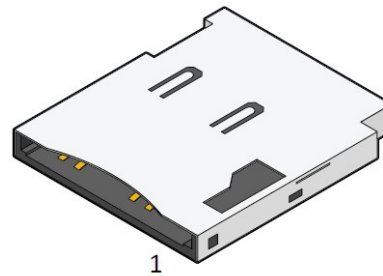

Figure 42: MicroSD card slot

Table 21: MicroSD card slot pinouts

A.4.26 Power LED

The VIA VAB-935 carrier board is equipped with a Power LED on the front I/O panel. The Power LED is used to indicate power status. The diagram of the Power LED is shown below.

Power LED Behavior	
Power On	ON
System Suspend/Power Off	OFF

Table 22: Power LED behavior

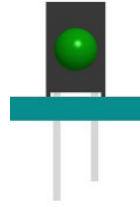

Figure 43: Power button

A.4.27 DIO Port

The VIA VAB-935 carrier board is equipped with a DIO port on the front I/O panel. The DIO port is used for digital input/output control. The pinouts of the DIO port are shown below.

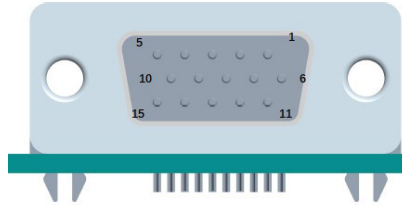

Figure 44: DIO port

Pin	Signal	Pin	Signal	Pin	Signal
1	DIO_GPIO1	6	DIO_GPIO6	11	DIO_GPIO9
2	DIO_GPIO2	7	DIO_GPIO7	12	DIO_GPIO10
3	DIO_GPIO3	8	GND	13	3.3V power
4	DIO_GPIO4	9	Download Key	14	3.3V power
5	DIO_GPIO5	10	DIO_GPIO8	15	GND

Table 23: DIO port pinouts

Appendix B Installing PCIe Mini Card Accessories

This chapter provides you with information on how to install a PCIe Mini Card into the miniPCIe slot on the VIA VAB-935 carrier board. It is recommended to use a grounded wrist strap before handling computer components. Electrostatic discharge (ESD) can damage some components.

B.1 Installing a PCIe Mini Card into the miniPCIe Slot

Step 1

Align the notch on the PCIe Mini Card with its counterpart on the miniPCIe slot on the VIA VAB-935 carrier board. Then insert the module at a 30° angle.

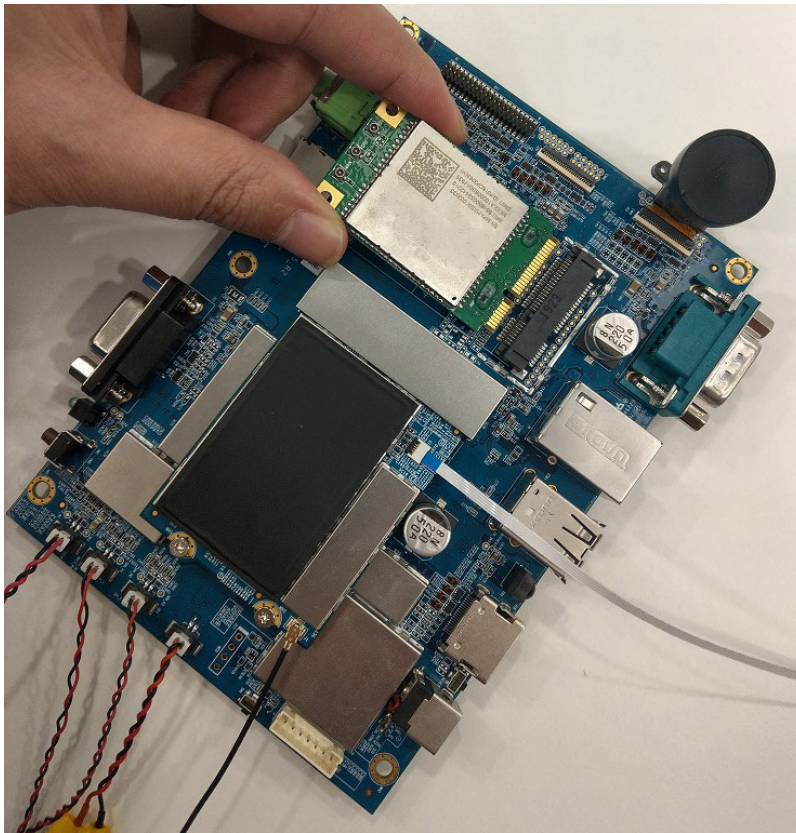

Figure 45: Installing a PCIe Mini Card

Step 2

Once the PCIe Mini Card has been fully inserted, push down the module until the screw holes align with the standoff holes and then secure the module with two screws provided with the PCIe Mini Card accessory.

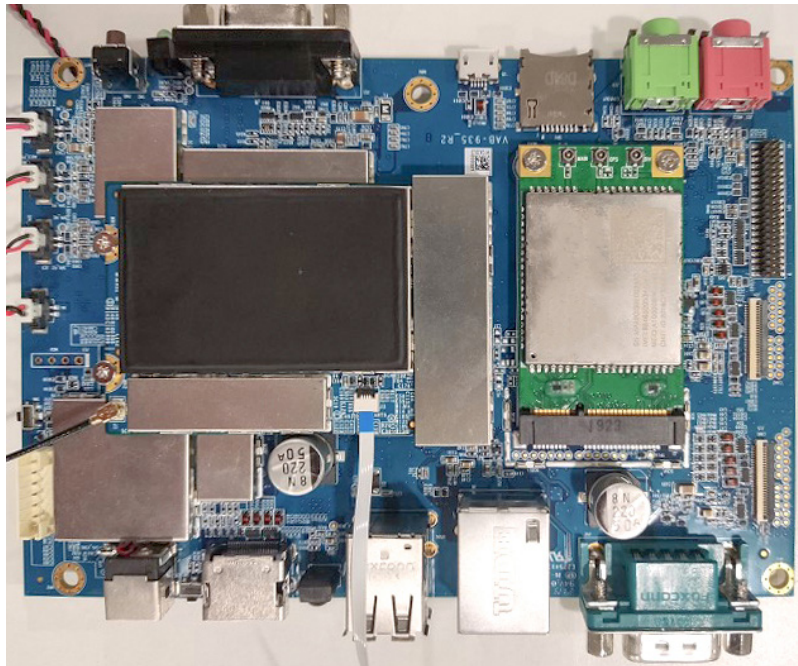

Figure 46: Securing the PCIe Mini Card

Appendix C Connecting LCD Display

This chapter provides you with information on how to connect the 10.1" TFT-LCD display to the VIA VAB-935 carrier board.

C.1 Connecting the TFT-LCD Display

Step 1

Attach the 39-pin FFC cable of the MIPI LCD display to the MIPI DSI connector labeled 'J7' on the VIA VAB-935 carrier board.



Note:

'J7' is a top contact type cable.



Figure 47: Connecting the 39-pin FFC cable of the TFT-LCD display to 'J7'

Step 2

Attached the 30-pin FFC cable of the Touch panel to the connector labeled 'J9' on the VIA VAB-935 carrier board, as shown in the diagram below.

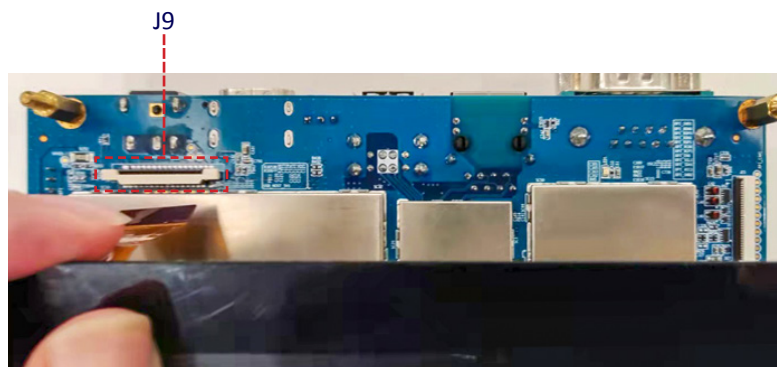

Figure 48: Connecting the 30-pin FFC cable of the Touch panel to 'J9'



Note:

To prevent the LCD metal shielding shorting the bottom PCBA pin, it is highly recommend to add a layer of insulation to prevent direct contact.



Taiwan Headquarters

1F, 531 Zhong-zheng Road,
Xindian Dist., New Taipei City 231
Taiwan

Tel: 886-2-2218-5452
Fax: 886-2-2218-9860
Email: embedded@via.com.tw



USA

940 Mission Court
Fremont, CA 94539,
USA

Tel: 1-510-687-4688
Fax: 1-510-687-4654
Email: embedded@viatech.com



Japan

3-15-7 Ebisu MT Bldg. 6F,
Higashi, Shibuya-ku
Tokyo 150-0011
Japan

Tel: 81-3-5466-1637
Fax: 81-3-5466-1638
Email: embedded@viatech.co.jp



China

Tsinghua Science Park Bldg. 7
No. 1 Zongguancun East Road,
Haidian Dist., Beijing, 100084
China

Tel: 86-10-59852288
Fax: 86-10-59852299
Email: embedded@viatech.com.cn



Europe

Email: embedded@via-tech.eu